

Battery Cables — 5.4L (4V)

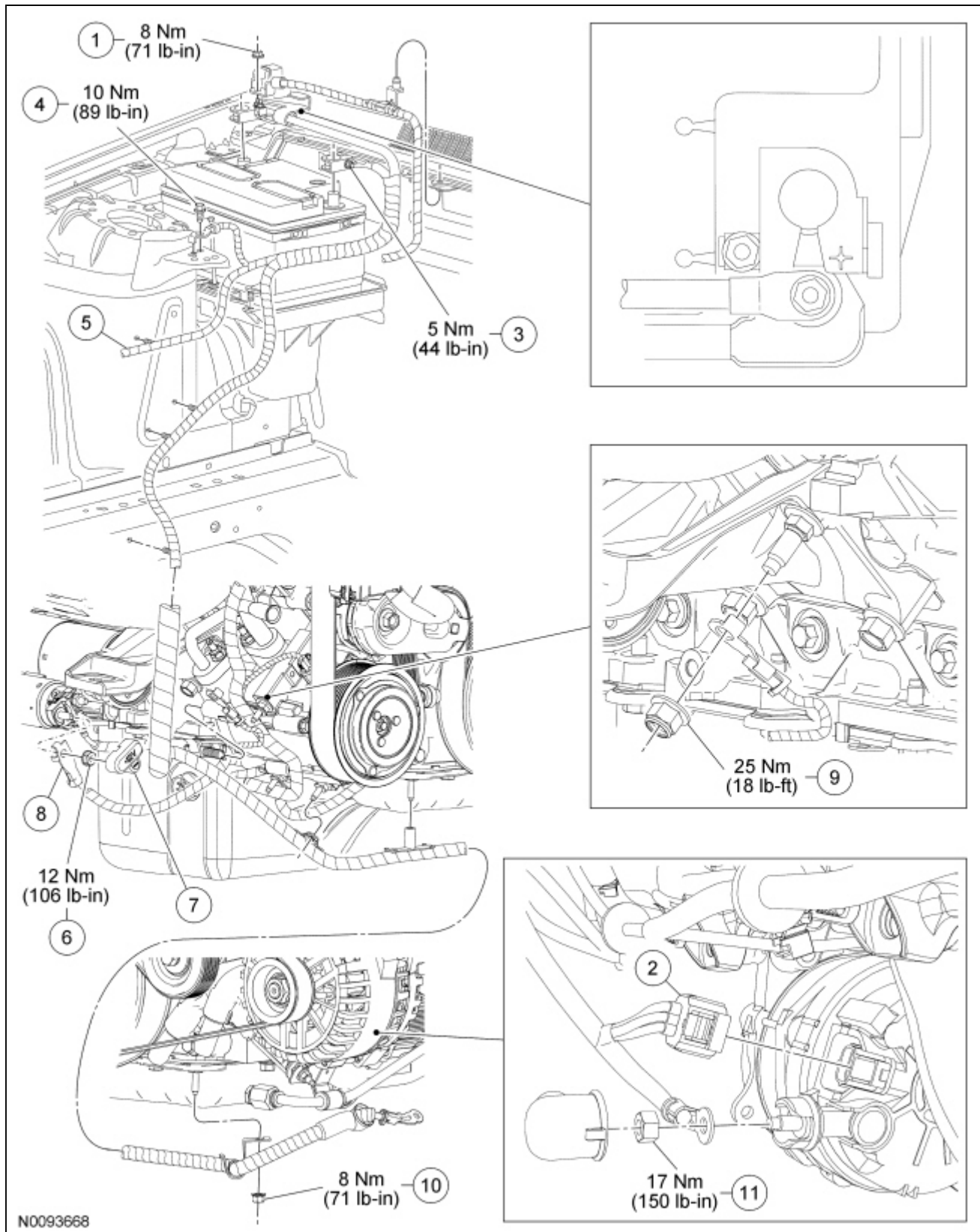

N0093668

Item	Part Number	Description
1	W711953	Generator harness B+ terminal nut
2	—	Generator harness terminal (part of 14300)

3	—	Battery cable terminal bolt (part of 14300)
4	W712583	Battery ground cable body bolt
5	—	Battery harness-to-distribution box
6	W706414	Starter solenoid positive cable terminal nut
7	11N087	Starter solenoid terminal cover
8	—	Starter solenoid positive cable terminal (part of 14300)
9	W520213-S440	Battery ground cable engine terminal nut
10	W705790-S901	Battery cable harness locator nut
11	W705790-S901	Battery cable terminal nut

Removal and Installation

1. With the vehicle in NEUTRAL, position it on a hoist. For additional information, refer to [Section 100-02](#).
2. Disconnect the battery. For additional information, refer to [Battery Disconnect](#) in this section.
3. Position the positive battery terminal cover aside, remove the nut and position the generator harness terminal aside.
 - To install, tighten to 17 Nm (106 lb-in).
4. Remove the locator from the dash panel.
5. Remove the starter solenoid terminal cover.
6. Remove the nut and position the starter solenoid positive cable terminal aside.
 - To install, tighten to 12 Nm (106 lb-in).
7. Remove the nut and position the battery ground cable engine terminal aside.
 - To install, tighten to 25 Nm (18 lb-ft).
8. Remove the starter solenoid wire harness locator from the A/C compressor.
9. Remove the battery cable harness locators from the body.
10. Remove the battery cable harness locators from the oil pan.
11. Remove the 2 battery cable harness locators from the RH strut tower.
12. Remove the bolt and position the battery ground cable body terminal aside.
 - To install, tighten to 10 Nm (89 lb-in).
13. Remove the battery cable harness locator from the battery tray.
14. Remove the battery cable harness locator from the RH strut tower.
15. Open the Bussed Electrical Center (BEC) cover, remove the bolt and position the [BEC](#) terminal aside.
 - To install, tighten to 10 Nm (89 lb-in).
16. Remove the battery cables.
17. To install, reverse the removal procedure.

